

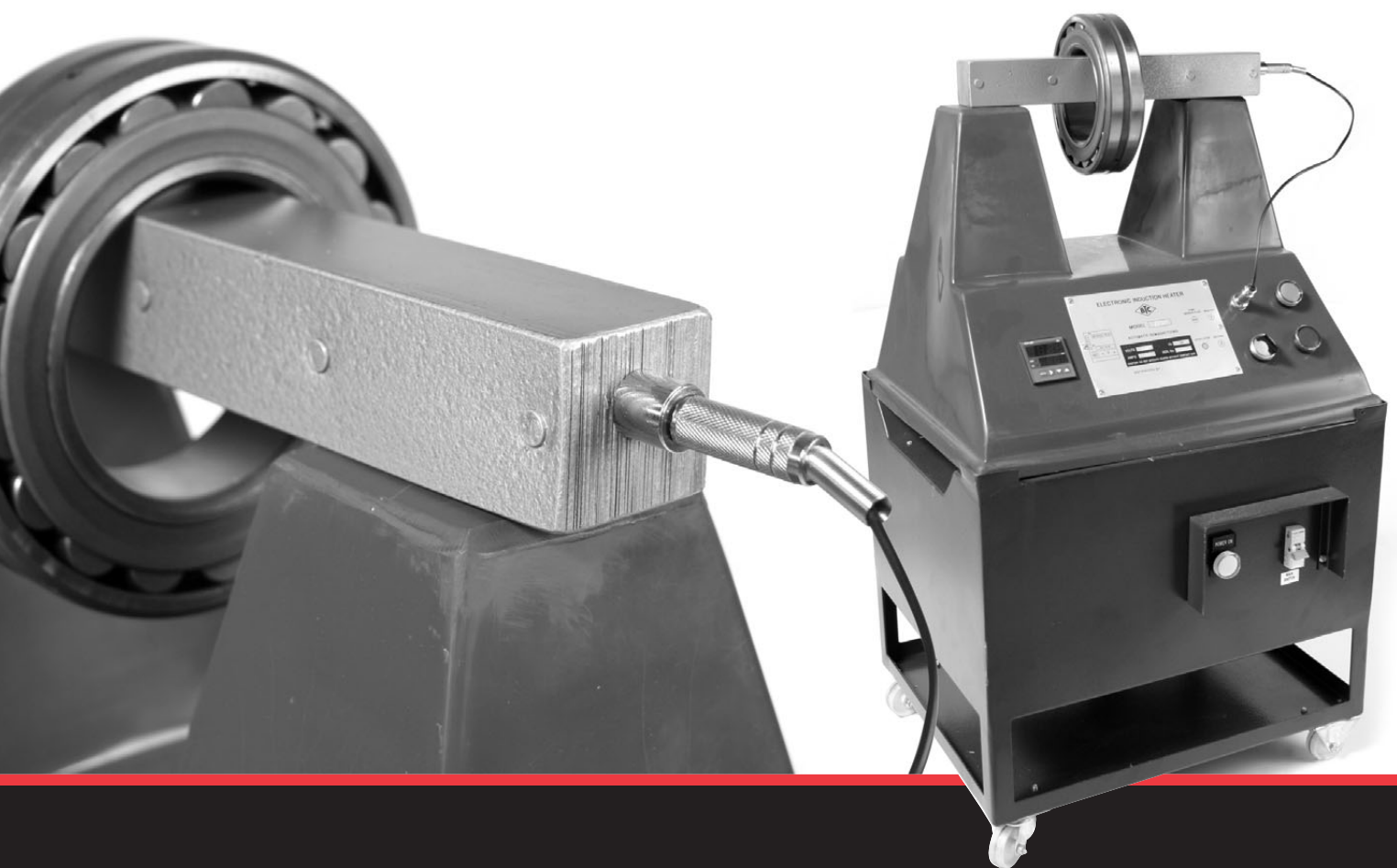

BEARING MAN GROUP



INDUCTION BEARING HEATERS

Overview

FEATURES & DIMENSIONS

FEATURES:

- Fast, Uniform Heating**
 Induction heating reduces mounting time and cost.
- No Oil Tanks Required**
 Since no oil is necessary, there can be no spills or other mess and bearings remain clean.
- Safe Operation**
 Since there are no flames, there are no fire hazards and an internal circuit breaker guards against an electrical short.
- Compact and Light**
 Most bearing heaters are light enough to be carried easily and used any place (with trolleys on Models 030 & 050)
- Automatic Temperature Control**
 A thermostatic control can be set at any temperature up to 130°C and a constant temperature is maintained.
- Automatic Demagnetizing**
 When the heating is finished, the bearing is quickly and automatically demagnetized.
- Electronic Control**
 Soft start and current limiter.
- Versatility**
 Besides bearings, other metallic rings such as inner ring spacers can also be heated for shrink fitting or for other purposes.

Dimensions	Model 020	Model 030	Model 050
A - Distance between supports (top)	105mm	185mm	285mm
B - Distance between supports (bottom)	95mm	135mm	215mm
C - Height of supports	110mm	170mm	240mm
D - Total heights	275mm	330mm	445mm
E - Width	330mm	480mm	680mm
Weight of heater	29kg	56kg	104kg
Weight of trolley	N/A	23kg	35kg

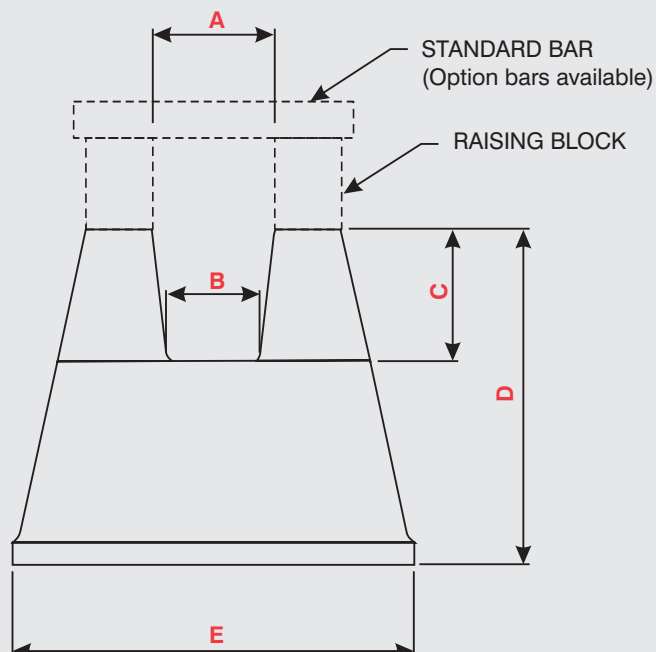

MODEL 020 (SMALL HEATER)

- Operating Voltage - 220 Volts
- Frequency - 50Hz
- Power consumption - 10 Amps max
- Bearing Bore Size - 25mm upwards

STANDARD BAR SIZES

Dimensions

- (1) 15 x 15 x 230mm
- (2) 40 x 40 x 230mm
- (3) 57 x 57 x 230mm

Min bearing ID

- 22mm
- 58mm
- 82mm

OPTION BAR SIZES

Dimensions

- (1) 25 x 25 x 230mm
- (2) 35 x 35 x 230mm
- (3) 42 x 42 x 230mm

Min bearing ID

- 37mm
- 51mm
- 60mm

- Raising Blocks - (1) 55 x 55 x 75mm high (Optional)



MODEL 030 (MEDIUM HEATER)

- Operating Voltage - 220 Volts
- Frequency - 50Hz
- Power consumption - 20 Amps max
- Bearing Bore Size - 60mm upwards

STANDARD BAR SIZES

Dimensions

- (1) 42 x 42 x 340mm
- (2) 70 x 70 x 340mm

Min bearing ID

- 60mm
- 100mm

OPTION BAR SIZES

Dimensions

- (1) 15 x 15 x 340mm
- (2) 17 x 17 x 340mm
- (3) 20 x 20 x 340mm
- (4) 30 x 30 x 340mm

Min bearing ID

- 22mm
- 25mm
- 30mm
- 44mm

- Raising Blocks - (1) 70 x 70 x 115mm high (Optional)



MODEL 050 (LARGE HEATER)

- Operating Voltage - 380 Volts
- Frequency - 50Hz
- Power consumption - 30 Amps max
- Bearing Bore Size - 80mm upwards

STANDARD BAR SIZES

Dimensions

- (1) 56 x 56 x 480mm
- (2) 90 x 90 x 480mm

Min bearing ID

- 80mm
- 130mm

OPTION BAR SIZES

Dimensions

- (1) 35 x 35 x 480mm
- (2) 70 x 70 x 480mm

Min bearing ID

- 51mm
- 100mm

- Raising Blocks - (1) 90 x 90 x 150mm high (Optional)



24 HR TOLL-FREE EMERGENCY
BRANCH HELPLINE:

0800 022 224

WEBSITE:

www.bmgworld.net



BEARING MAN GROUP

BEARINGS • SEALS • POWER TRANSMISSION • BELTING
DRIVES & MOTORS • FASTENERS • FILTRATION • HYDRAULICS

SANS ISO 9001:2008